

Ozen
Refrigerated
Air Drying
Systems

Ozen
Desiccant
Air Drying
Systems



Ozen Air
Filtration / Water
Separation and
Service Elements

Nitrogen
Generator

AIR TREATMENT EQUIPMENT



THE DETAILS THAT DELIVER THE RIGHT RESULTS...

EXPERIENCE

Ozen Air Technology, with its industry experience of half-a-century and its large portfolio of compressed air products, provides, reliable, efficient and smart solutions.

TRUST

Ozen's dedication to customer satisfaction has helped the company to build lasting relationships of trust and loyalty with its customers.

DURABLE AND EFFICIENT

All of the compressed air equipment in Ozen's portfolio have proven their durability under toughest conditions. They provide high-quality, high-efficiency air.

QUALITY

Manufacturing consistently high-quality products is one of Ozen's fundamental tenets. To that end, Ozen continuously enhances its quality policies.





TECHNOLOGY

Ozen Air Technology is innovative. It always uses up-to-date technologies in compliance with world-standards.

R & D

With its creative team and competent infrastructure, Ozen is capable of developing its own technology through collaborations with several universities.

STRONG SERVICE NETWORK

Ozen Air Technology believes in maintainability. Its customers can enjoy uninterrupted manufacturing thanks to its accessible, fast and reliable service network.

COMPETITIVE

Ozen Air Technology acts in favor of its customers. Providing them with leverage is one of Ozen's strong suits.

RESPECT FOR THE ENVIRONMENT

Striving for a sustainable future, Ozen Air Technology selects for environmentally friendly practices and takes all necessary precautions while structuring its work processes.



Ozen Refrigerated
Air Drying Systems



ODRD Series Digital Cycling Refrigerated Air Dryers

ODRD (10-5000 scfm)



Supply of clean and dry air is essential for all companies that require air for their production. In order not to compromise the quality of the end product and to protect the equipment from corrosion, the air that comes out of the compressors must be filtered to clean it from all kinds of dirt and humidity.

Ozen Air Technology's refrigerated air dryers ensure the quality and continuity of your production by eliminating the particles and humidity from your compressed air system.

Ozen only uses environmentally friendly R134a gas in its dryers. Thanks to the thermodynamic properties of R134a, which is ideal for both low and high temperature applications, it is possible to operate at lower pressures than other dryers. Since it is designed to accommodate extreme tropical climates, the dryer provides high performance at ambient temperatures of up to 140 °F. With the Digi-Pro control unit, it is easy to monitor the actual dew-point and determine the dryer's periodical service and maintenance needs.

The strategic positioning of the electrical panel makes it easily accessible without having to open the product covers.

Compact design

- The aluminum plate heat exchanger, which is standard, generates minimum pressure drop, maximum heat transmission, and high-performance water separation.
- Compact design provides ease of installation and small space compatibility.
- Refrigerant cycle's Suction/Evaporation and Discharge/Condensation pressure gauges are connected to the cooling cycle.
- Electrical and mechanical panels are separated.
- Easy access to the electrical panel of the product.

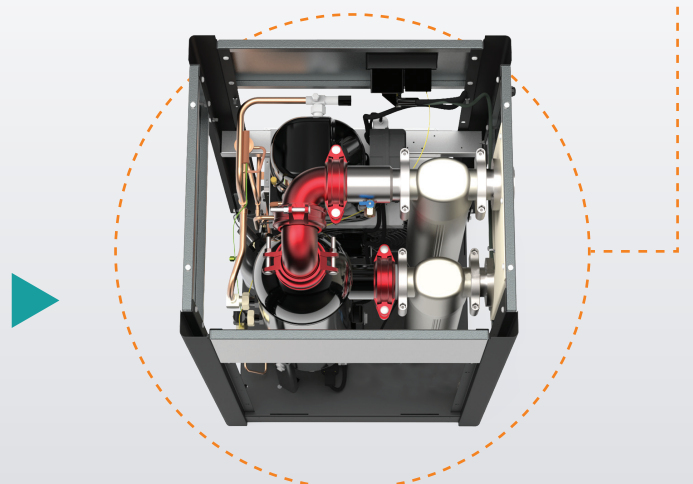

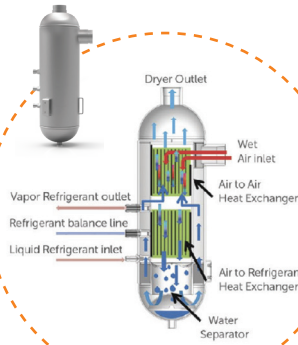

Integrated filters

- Standard filters located inside the dryer eliminate the need to install separate filters and external piping at the inlet and outlet points of the dryer. (up to ODRD 1100)
- Oversized (above capacity) filters are chosen to extend lifetime.

Ease of service

- Easy service and maintenance, thanks to the screwless panels with plastic handles.
- Filter components that can be easily replaced in small areas.
- Ease of assembly and disassembly with grooved couplings and pipe connections.
- Standard spare manual discharge.
- Service, maintenance and operating hour counter notification signals.
- Manual discharge valves on the filters make it possible to instantly lower the pressure during service.

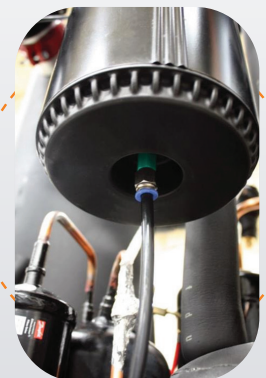

ODRD Series Digital Cycling Refrigerated Air Dryers

ODRD (10-5000 scfm)

Digi-Pro Digital Control Unit

Digi-Pro digital control unit is standard in models between ODRD 10 and ODRD 425

- Energy saving mode
- Digital dew-point gauge
- Temperature unit selection (Celcius/Fahrenheit)
- Ability to get status reports
- Periodical maintenance indicator
- Time counter

ESD Digital Control Unit

ESD digital control unit is standard in models between ODRD 550 and ODRD 5000.

- Saves energy
- Automatic shutdown/economy mode when the air does not receive any air.
- Multi-parameter gauges
- Alarm signals



Technical Specifications

Model	Capacity	Voltage	Coupling Size	Pressure Drop	Integrated Filter	Replacement Filter Type	Dimensions (inch)			Weight
	scfm	V					W	L	H	
ODRD-10	10	115/1/60	1/2" NPT	1.5	included	ODD-27-KIT	17	16	23	71
ODRD-15	15	115/1/60	1/2" NPT	1.7	included	ODD-27-KIT	17	16	23	71
ODRD-25	25	115/1/60	1/2" NPT	2.8	included	ODD-27-KIT	17	16	23	71
ODRD-30	30	115/1/60	1/2" NPT	2.8	included	ODD-41-KIT	17	16	23	77
ODRD-35	35	115/1/60	3/4" NPT	1.2	included	ODD-90-KIT	19	18	33	113
ODRD-60	60	115/1/60	3/4" NPT	1.6	included	ODD-90-KIT	19	18	33	117
ODRD-75	75	115/1/60	3/4" NPT	2.3	included	ODD-90-KIT	19	18	33	121
ODRD-100	100	115/1/60	1 1/2" NPT	1.6	included	ODD-300-KIT	22	20	35	172
ODRD-125	125	115/1/60	1 1/2" NPT	2.2	included	ODD-300-KIT	22	20	35	183
ODRD-140	140	230/1/60	1 1/2" NPT	2.8	included	ODD-300-KIT	22	20	35	190
ODRD-175	175	230/1/60	2" NPT	1.6	included	ODD-500-KIT	27	26	46	352
ODRD-200	200	230/1/60	2" NPT	1.9	included	ODD-700-KIT	27	26	46	363
ODRD-250	250	230/1/60	2" NPT	1.6	included	ODD-700-KIT	29	38	54	450
ODRD-350	350	230/1/60	2" NPT	2.6	included	ODD-700-KIT	29	38	54	485
ODRD-425	425	230/1/60	2" NPT	2.9	included	ODD-700-KIT	29	38	54	506
ODRD-550	550	460/3/60	3" NPT	2.0	included	ODD-1100-KIT	32	38	58	595
ODRD-700	700	460/3/60	3" NPT	2.5	included	ODD-1100-KIT	32	38	58	627
ODRD-900	900	460/3/60	3" NPT	1.7	included	ODD-1600-KIT	31	46	68	863
ODRD-1100	1100	460/3/60	3" NPT	2.2	included	ODD-1600-KIT	31	46	68	902
ODRD-1350	1350	460/3/60	3" NPT	1.7	included	ODD-1600-KIT	34	55	70	1082
ODRD-1500	1500	460/3/60	3" NPT	1.9	included	ODD-1600-KIT	34	55	70	1145
ODRD-2000	2000	460/3/60	4" FLANGE	2.7	OFLF-2500 P/X/Y/A	OFLFe-2500 P/X/Y/A	43	58	76	1532
ODRD-2350	2350	460/3/60	4" FLANGE	2.8	OFLF-2500 P/X/Y/A	OFLFe-2500 P/X/Y/A	43	58	76	1580
ODRD-2750	2750	460/3/60	6" FLANGE	2.5	OFLF-3800 P/X/Y/A	OFLFe-3800 P/X/Y/A	42	87	76	1980
ODRD-3000	3000	460/3/60	6" FLANGE	2.5	OFLF-3800 P/X/Y/A	OFLFe-3800 P/X/Y/A	42	87	76	2035
ODRD-3600	3600	460/3/60	6" FLANGE	2.5	OFLF-3800 P/X/Y/A	OFLFe-3800 P/X/Y/A	36	89	78	2145
ODRD-4000	4000	460/3/60	8" FLANGE	2.5	OFLF-6500 P/X/Y/A	OFLFe-6500 P/X/Y/A	36	89	78	2420
ODRD-5000	5000	460/3/60	8" FLANGE	2.5	OFLF-6500 P/X/Y/A	OFLFe-6500 P/X/Y/A	61	101	83	3080

- Max. working pressure: 230 psig.
- Max. ambient temperature: 120 °F.
- Max. inlet temperature: 140 °F
- Different voltage options are available.

CORRECTION FACTORS FOR ODRD DRYERS										
Inlet Temperature (°F)	85	90	95	100	110	120	130	140	150	-
X1	1.20	1.14	1.08	1.00	0.75	0.60	0.50	0.45	0.35	-
Ambient Temperature (°F)	60	80	90	100	105	110	115	120	-	-
X2	1.12	1.08	1.06	1.00	0.96	0.9	0.8	0.65	-	-
Pressure (psi)	60	60	75	100	115	125	150	175	200	230
X3	0.75	0.77	0.85	1	1.06	1.1	1.16	1.25	1.3	1.35

ODRC Series Cycling (Thermal Mass) Refrigerated Air Dryers



ODRC (100-5000 scfm)

ODRC series cycling air dryers cool down a special kind of fluid and store it in a stainless tank. This fluid, then, cools the compressed air by cycling inside the dryer. This technology saves energy in cases where the flow of compressed air tends to fluctuate.

In order to eliminate the risk of corrosion, product components that are in contact with the cold fluid, such as the heat exchanger, water tank and water pump, are made out of stainless steel or aluminum.



MCY Air Dryers Power Saving Chart

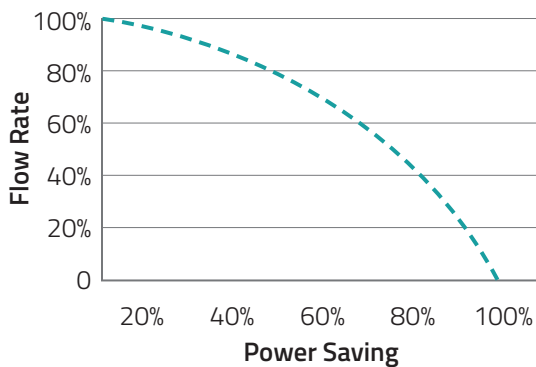

All components that are exposed to cooling liquid are either stainless steel (Heat exchanger, Tank, Pump) or Aluminum (Dryer heat exchanger) Therefore there is no risk of corrosion

Technical Specifications

Model	Capacity	Voltage	Coupling Size	Integrated Filter	Replacement Filter Type	Dimensions (inch)		
	scfm	V				W	L	H
ODRC-100	100	115/1/60	1 1/2" NPT	included	ODD-300-KIT	25.50	26.65	48.35
ODRC-125	125	115/1/60	1 1/2" NPT	included	ODD-300-KIT	25.50	26.65	48.35
ODRC-140	140	230/1/60	1 1/2" NPT	included	ODD-300-KIT	25.50	26.65	48.35
ODRC-175	175	230/1/60	2" NPT	included	ODD-300-KIT	28.55	33.65	59.25
ODRC-200	200	230/1/60	2" NPT	included	ODD-700-KIT	28.55	33.65	59.25
ODRC-250	250	230/1/60	2" NPT	included	ODD-700-KIT	28.75	32.70	69.50
ODRC-350	350	460/3/60	2" NPT	included	ODD-700-KIT	28.75	32.70	69.50
ODRC-425	425	460/3/60	2" NPT	included	ODD-700-KIT	28.75	32.70	69.50
ODRC-550	550	460/3/60	3" NPT	included	ODD-1100-KIT	31.50	61.00	68.50
ODRC-700	700	460/3/60	3" NPT	included	ODD-1100-KIT	31.50	61.00	68.50
ODRC-900	900	460/3/60	3" NPT	included	ODD-1600-KIT	34.65	51.80	70.50
ODRC-1100	1100	460/3/60	3" NPT	included	ODD-1600-KIT	34.65	51.80	70.50
ODRC-1350	1350	460/3/60	3" NPT	included	ODD-1600-KIT	33.50	55.00	72.45
ODRC-1500	1500	460/3/60	3" NPT	included	ODD-1600-KIT	33.50	55.00	72.45
ODRC-2000	2000	460/3/60	4" FLANGE	OFLF-2500 P/X/Y/A	OFLFe-2500 P/X/Y/A	42.50	63.80	78.55
ODRC-2350	2350	460/3/60	4" FLANGE	OFLF-2500 P/X/Y/A	OFLFe-2500 P/X/Y/A	42.50	63.80	78.55
ODRC-2750	2750	460/3/60	6" FLANGE	OFLF-3800 P/X/Y/A	OFLFe-3800 P/X/Y/A	42.00	86.25	80.00
ODRC-3000	3000	460/3/60	6" FLANGE	OFLF-3800 P/X/Y/A	OFLFe-3800 P/X/Y/A	42.00	86.25	80.00
ODRC-3600	3600	460/3/60	6" FLANGE	OFLF-3800 P/X/Y/A	OFLFe-3800 P/X/Y/A	47.25	114.20	83.50
ODRC-4000	4000	460/3/60	8" FLANGE	OFLF-6500 P/X/Y/A	OFLFe-6500 P/X/Y/A	47.25	114.20	83.50
ODRC-5000	5000	460/3/60	8" FLANGE	OFLF-6500 P/X/Y/A	OFLFe-6500 P/X/Y/A	61.00	100.50	85.45

CORRECTION FACTORS FOR ODDR DRYERS										
Inlet Temperature (°F)	85	90	95	100	110	120	130	140	150	-
X1	1.20	1.14	1.08	1.00	0.75	0.60	0.50	0.45	0.35	-
Ambient Temperature (°F)	60	80	90	100	105	110	115	120	-	-
X2	1.12	1.08	1.06	1.00	0.96	0.9	0.8	0.65	-	-
Pressure (psi)	50	60	75	100	115	125	150	175	200	230
X3	0.75	0.77	0.85	1	1.06	1.1	1.16	1.25	1.3	1.35

- Max. working pressure: 230 psig.
- Max. ambient temperature: 120 °F.
- Max. inlet temperature: 140 °F
- Different voltage options are available.

ODRH Series High Temperature Refrigerated Air Dryers

ODRH (15-100 scfm)



In compressors whose air outlet temperature is above 240 °F and designed without a cooler, the air discharging from the compressor needs to be cooled down. By lowering the inlet temperature, ODRH series high temperature refrigerated air dryers create a consistent dew-point and ensure high performance.

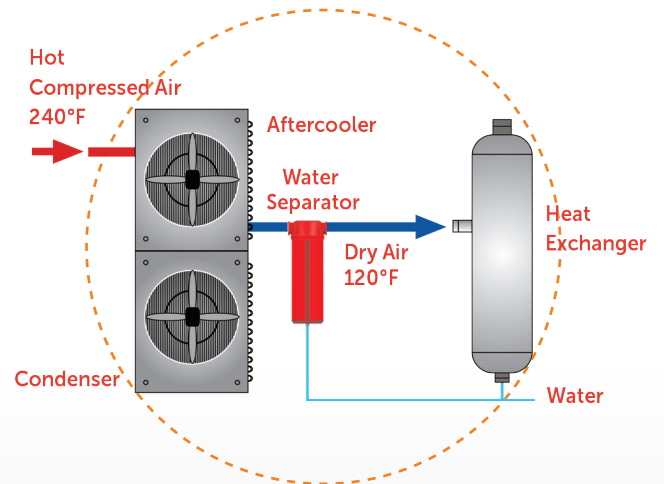

Technical Specifications

Model	Capacity	Voltage	Coupling Size	Max. Pressure	Max. Ambient Temp.	Max. Inlet Temp.	Dimensions (inch)		
	scfm						V	psi	°F
ODRH-15	15	115/1/60	1/2" NPT	230	120	240	17.5	17.5	37.6
ODRH-25	25	115/1/60	1/2" NPT	230	120	240	17.5	17.5	37.6
ODRH-35	35	115/1/60	1/2" NPT	230	120	240	17.5	17.5	37.6
ODRH-50	50	115/1/60	3/4" NPT	230	120	240	17.5	17.5	37.6
ODRH-75	75	115/1/60	3/4" NPT	230	120	240	20	24.6	35.8
ODRH-100	100	115/1/60	3/4" NPT	230	120	240	20	24.6	35.8

CORRECTION FACTORS FOR ODRD DRYERS													
Inlet Temperature (°F)	39	50	61	70	79	90	100	149	180	199	208	219	240
X1	1.40	1.40	1.40	1.40	1.35	1.30	1.27	1.06	1.00	0.85	0.78	0.75	0.70
Ambient Temperature (°F)	39	50	61	75	84	95	100	104	115	120	-	-	-
X2	1.10	1.10	1.10	1.10	1.07	1.03	1	0.96	0.82	0.55	-	-	-
Pressure (psi)	60	73	87	102	115	123	145	160	175	189	203	230	-
X3	0.70	0.75	0.80	0.83	0.86	0.90	0.93	0.96	1	1.10	1.12	1.15	-

▪ Different voltage options are available.

ODRD-P Series High Pressure Refrigerated Air Dryers



ODRD-P (15-1700 scfm)



← HIGH PRESSURE 580 PSI

Standard 3 IN 1 Mono block Steel Heat Exchanger

- Compressed Air
- Refrigerant
- Drain

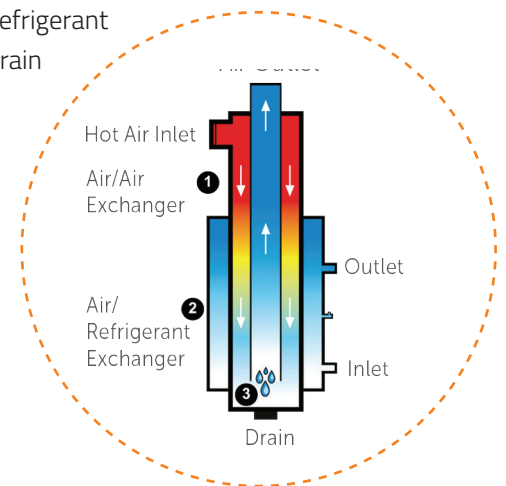

Fin Exchanger

- High surface of exchange from 10 to 20 times larger than the competition
- Direct transfer of the cold from the refrigerant to the compressed air
- No exterior connection between economizer and separator
- Strong and robust built heat exchanger
- Special anti-corrosion treatment
- Perfect thermal insulation
- Small volume of refrigerant

The Separator Efficiency

- Double centrifugation due to the bottom fin
- Reserved direction for the compressed air
- Gravity effect to the condensed water
- Special anti-return system
- Separator integrated to the system

Frigorific Circuit

- Two valve regulation system (thermal and by-pass), allowing to fill properly the exchanger and giving then a max. temperature to the exchanger
- High quality security test of potential leakage
- Use of Tecumseh hermetic compressor as standard
- High quality, long lasting components
- Quick start and reaction time

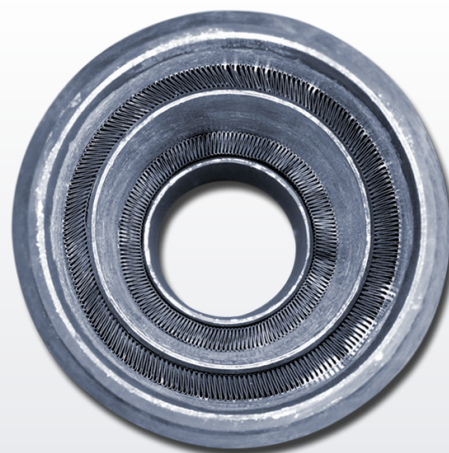

ODRD-P Series High Pressure Refrigerated Air Dryers

ODRD-P (15-1700 scfm)

Technical Specifications

Model	Capacity	Voltage	Coupling Size	Filter Type	Replacement Filter Type
	scfm	V			
ODRD-P-25	25	115/1/60	3/4"	OFLHG - 42P/X/Y/A	OFLHGe-42P/X/Y/A
		230/1/60			
ODRD-P-40	40	115/1/60	3/4"	OFLHG - 42P/X/Y/A	OFLHGe-42P/X/Y/A
		230/1/60			
ODRD-P-70	70	115/1/60	3/4"	OFLHG - 125P/X/Y/A	OFLHGe-125P/X/Y/A
		230/1/60			
ODRD-P-100	100	115/1/60	3/4"	OFLHG - 125P/X/Y/A	OFLHGe-125P/X/Y/A
		230/1/60			
ODRD-P-140	140	115/1/60	1 1/4"	OFLHG - 250P/X/Y/A	OFLHGe-250P/X/Y/A
		230/1/60			
ODRD-P-190	190	115/1/60	1 1/4"	OFLHG - 250P/X/Y/A	OFLHGe-250P/X/Y/A
		230/1/60			
ODRD-P-235	235	115/1/60	1 1/4"	OFLHG - 250P/X/Y/A	OFLHGe-250P/X/Y/A
		230/1/60			
ODRD-P-270	270	230/1/60	1 1/4"	OFLHG - 350P/X/Y/A	OFLHGe-350P/X/Y/A
		230/3/60 & 460/3/60			
ODRD-P-350	350	230/1/60	1 1/4"	OFLHG - 350P/X/Y/A	OFLHGe-350P/X/Y/A
		230/3/60 & 460/3/60			
ODRD-P-425	425	230/1/60	1 1/4"	OFLHG - 500P/X/Y/A	OFLHGe-500P/X/Y/A
		230/3/60 & 460/3/60			
ODRD-P-470	470	230/1/60	2"	OFLHG - 500P/X/Y/A	OFLHGe-500P/X/Y/A
		230/3/60 & 460/3/60		Water Condanser	ODRD-P-470W
ODRD-P-550	550	230/1/60	2"	OFLHG - 940P/X/Y/A	OFLHGe-940P/X/Y/A
		230/3/60 & 460/3/60		Water Condanser	ODRD-P-550W
ODRD-P-700	700	230/1/60	2"	OFLHG - 940P/X/Y/A	OFLHGe-940P/X/Y/A
		230/3/60 & 460/3/60		Water Condanser	ODRD-P-700W
ODRD-P-750	750	460/3/60	2"	OFLHG - 940P/X/Y/A	OFLHGe-940P/X/Y/A
				Water Condanser	ODRD-P-750W
ODRD-P-850	850	460/3/60	2"	OFLHG - 940P/X/Y/A	OFLHGe-940P/X/Y/A
				Water Condanser	ODRD-P-850W
ODRD-P-1000	1000	460/3/60	2 1/2"	OFLHG - 1470P/X/Y/A	OFLHGe-1470P/X/Y/A
				Water Condanser	ODRD-P-1000W
ODRD-P-1200	1200	460/3/60	2 1/2"	OFLHG - 1470P/X/Y/A	OFLHGe-1470P/X/Y/A
				Water Condanser	ODRD-P-1200W
ODRD-P-1300	1300	460/3/60	2 1/2"	OFLHG - 1470P/X/Y/A	OFLHGe-1470P/X/Y/A
				Water Condanser	ODRD-P-1300W
ODRD-P-1400	1400	460/3/60	2 1/2"	OFLHG - 1765P/X/Y/A	OFLHGe-1765P/X/Y/A
				Water Condanser	ODRD-P-1400W
ODRD-P-1500	1500	460/3/60	2 1/2"	OFLHG - 1765P/X/Y/A	OFLHGe-1765P/X/Y/A
				Water Condanser	ODRD-P-1500W
ODRD-P-1700	1700	460/3/60	2 1/2"	included	OFLHGe-1765P/X/Y/A
				Water Condanser	ODRD-P-1700W

CORRECTION FACTORS FOR ODRD DRYERS							
Inlet Temperature (°F)	80	85	90	95	100	110	120
X1	1.25	1.20	1.14	1.08	1.00	0.75	0.60
Ambient Temperature (°F)	60	70	80	90	100	110	115
X2	1.12	1.10	1.08	1.06	1.00	0.90	0.80
Pressure (psi)	290	360	435	505	580	650	-
X3	0.84	0.90	0.94	0.96	1.00	1.02	-

- Different voltage options are available.



Ozen Desiccant Air Drying Systems



ODMD Series Modular Desiccant Air Dryers

ODMD (3-240 scfm)

ODMD series desiccant dryers' light, modular design provides flexibility of installation. ODMD series dryers can easily satisfy special needs and they make installation and assembly simple since they only weigh half of standard dryers with tanks. The series, with its plug-and-play design, esthetic appearance and innovative build, is suitable for use wherever high-quality compressed air is needed.

The series, with a portfolio of products ranging from 3 cfm to 240 scfm, is an all-in-one package with a dew-point between $-40\text{ }^{\circ}\text{F}$ and $-94\text{ }^{\circ}\text{F}$; all you need is air inlet and outlet connections. Its highly engineered inlet valve and outlet manifold design guarantee the lowest pressure drop in the industry.

- Quick installation and maintenance
- Esthetic appearance with compact, lightweight design
- Protection against corrosion by aluminum body
- Floor, wall or countertop installation options
- Reliable electronic control panel





PLC Monitor

- Instant work process monitoring with user friendly indicators
- Command by remote control
- Remote signal capability

Technical Specifications

Model	Capacity	Voltage	Coupling Size	Max. Pressure	Dimensions (inch)			Weight
	scfm	V			L	W	H	
ODMD-3	3	115-230/1/60	1/2" NPT	230	13.2	12.6	22	37
ODMD-5	5	115-230/1/60	1/2" NPT	230	12.6	12.6	25	41
ODMD-10	10	115-230/1/60	1/2" NPT	230	12.6	12.6	35.5	59
ODMD-15	15	115-230/1/60	1/2" NPT	230	13.8	14.5	31.8	68
ODMD-20	20	115-230/1/60	1/2" NPT	230	13.8	14.5	43.6	92
ODMD-25	25	115-230/1/60	1/2" NPT	230	13.8	14.5	49.5	105
ODMD-30	30	115-230/1/60	1/2" NPT	230	13.8	14.5	59.4	118
ODMD-40	40	115-230/1/60	1 1/2" NPT	230	19.5	16.1	49.2	143
ODMD-50	50	115-230/1/60	1 1/2" NPT	230	19.5	16.1	55.1	156
ODMD-60	60	115-230/1/60	1 1/2" NPT	230	19.5	16.1	68.8	171
ODMD-75	75	115-230/1/60	1 1/2" NPT	230	24.5	17	51.1	202
ODMD-100	100	115-230/1/60	1 1/2" NPT	230	24.5	22	58	264
ODMD-120	120	115-230/1/60	1 1/2" NPT	230	24.5	25	68.8	292
ODMD-180	180	115-230/1/60	1 1/2" NPT	230	28.9	16.1	59	409
ODMD-240	240	115-230/1/60	1 1/2" NPT	230	35	16.1	59	517

- Max. working pressure: 230 psig.
- Max. ambient temperature: 122 °F.
- Max. Inlet temperature: 122 °F
- Pressure Dew point -40 °F, optional -94 °F
- Different voltage options are available.

CORRECTION FACTORS FOR ODRD DRYERS															
Pressure (psi)	50	60	70	80	90	100	110	120	130	140	150	175	200	225	250
X1	0.56	0.65	0.74	0.83	0.91	1.00	1.06	1.08	1.12	1.16	1.20	1.29	1.37	1.45	1.52
Inlet Temperature (°F)	70	80	90	100	105	110	115	120	-	-	-	-	-	-	-
X2	1.12	1.09	1.06	1	0.93	0.86	0.8	0.75	-	-	-	-	-	-	-

ODHR Series Heatless Regenerative Desiccant Air Dryers

ODHR (300-5000 scfm)



ODHR series heatless desiccant dryers are designed to provide high-quality, dry, compressed air for critical applications such as the oil-gas, food-beverage and pharmaceutical industries. Heatless desiccant dryers that provide a constant dew point of $-40\text{ }^{\circ}\text{F}$ ensure flawless operation thanks to the reliable electronic controller on board. Equipped with special valves and high-quality desiccant, this series boasts the lowest pressure drop in the industry.

- This is a double-tank system.
- The first tank, which has high hygroscopic impact resistance and a large surface area, separates the moisture from the compressed air.
- The second tank simultaneously performs the drying process with regeneration. The tank with the saturated desiccant is dried with the help of super dry air at atmospheric pressure.
- The rate at which mufflers expel air can be adjusted according to the desired dew-point.
- No heater is used during this process.
- The pressure between the tanks is equalized to prevent desiccant wear.
- The air movements in the tanks are in reverse directions.

PLC control unit

- Dew point indicator
- User-friendly touch screen
- Real time monitoring of both the cycle and the valves
- Multi-language support

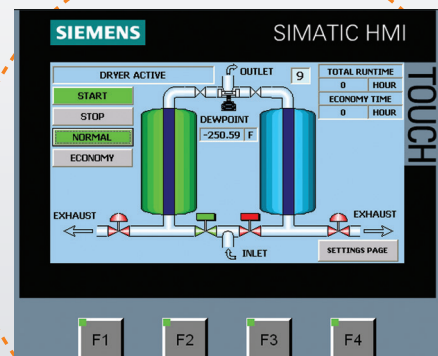



Active Alumina

- Fixed dew point with a special mix of desiccants.
- Active alumina or molecular sieve and silica gel, as chosen according to the application.

Technical Specifications

Model	Inlet Flow Rate scfm	Voltage V	Coupling Size	Pressure Drop psi	Max Working Pressure psi	Dimensions (inch)			Weight lbs
						L	W	H	
ODHR-300	300	115/1/60	1 1/2" NPT	≤2	200	40	24	87	1200
ODHR-400	400	115/1/60	1 1/2" NPT	≤2	200	46	26	88	1350
ODHR-500	500	115/1/60	2" NPT	≤2	200	46	26	88	1460
ODHR-600	600	115/1/60	2" NPT	≤2	200	46	26	88	1790
ODHR-800	800	115/1/60	3" NPT	≤2	200	55	48	105	2150
ODHR-1000	1000	115/1/60	3" NPT	≤2	200	55	48	105	2960
ODHR-1250	1250	115/1/60	3" NPT	≤2	200	60	50	109	3470
ODHR-1500	1500	115/1/60	3" NPT	≤2	200	60	50	109	4180
ODHR-2000	2000	115/1/60	3" NPT	≤2	200	70	62	115	4980
ODHR-2500	2500	115/1/60	4" NPT	≤2	200	70	62	115	5800
ODHR-3000	3000	115/1/60	4" NPT	≤2	200	80	70	120	6400
ODHR-4000	4000	115/1/60	6" NPT	≤2	200	90	80	122	9100
ODHR-5000	5000	115/1/60	6" NPT	≤2	200	98	86	120	11800

- Max. working pressure: 200 psig.
- Nominal working pressure: 100 psi.
- Max. ambient temperature: 120 °F.
- Max. Inlet temperature: 120 °F
- Pressure Dew point -40 °F, optional -100 °F
- Different voltage options are available.

Filter Efficiency Rating



CORRECTION FACTORS FOR ODRD DRYERS													
Pressure (psi)	50	60	70	80	90	100	110	120	130	140	150	175	200
X1	0.56	0.65	0.74	0.83	0.91	1.00	1.06	1.08	1.12	1.16	1.20	1.29	1.37
Inlet Temperature (°F)	70	80	90	100	105	110	115	120	-	-	-	-	-
X2	1.12	1.09	1.06	1	0.93	0.86	0.8	0.75	-	-	-	-	-

- All desiccant dryers are designed according to Pneurop conditions as per ISO7183.

ODBP Series Blower Purge Heated Desiccant Air Dryers

ODBP (500-10000 scfm)



The high-efficiency heater and the centrifugal blower motor perform the regeneration of the desiccant with no air loss. In the automatic system, the motor draws the atmospheric air in and dries it by passing it through the heater. The hot air flows in the reverse direction of the dryer air. Advanced electronic control system saves energy by enabling the adjustment of the dew-point and the regeneration.

Features

- Dew point indicator
- Remote control
- Computer control
- Status display
- Alarm and pressure indicator
- Low pressure alarm
- Minimum pressure check valve
- High pressure switches and warning
- Heated and heatless option

Technical Specifications

Model	Inlet Flow Rate cfm	Voltage V	Coupling Size	Pressure Drop psi	Max Working Pressure psi
ODBP-500	500	460/3/60	2" NPT	≤2	200
ODBP-600	600	460/3/60	2" NPT	≤2	200
ODBP-800	800	460/3/60	3" Flanged	≤2	200
ODBP-1000	1000	460/3/60	3" Flanged	≤2	200
ODBP-1250	1250	460/3/60	3" Flanged	≤2	200
ODBP-1500	1500	460/3/60	3" Flanged	≤2	200
ODBP-2000	2000	460/3/60	4" Flanged	≤2	200
ODBP-2500	2500	460/3/60	4" Flanged	≤2	200
ODBP-3000	3000	460/3/60	6" Flanged	≤2	200
ODBP-4000	4000	460/3/60	6" Flanged	≤2	200
ODBP-5000	5000	460/3/60	6" Flanged	≤2	200
ODBP-7000	7000	460/3/60	8" Flanged	≤2	200
ODBP-8000	8000	460/3/60	8" Flanged	≤2	200
ODBP-9000	9000	460/3/60	10" Flanged	≤2	200
ODBP-10000	10000	460/3/60	10" Flanged	≤2	200

- Max. working pressure: 200 psig.
- Max. ambient temperature: 120 °F.
- Max. inlet temperature: 100 °F
- Pressure Dew point: -40 °F

CORRECTION FACTORS FOR ODRD DRYERS													
Pressure (psi)	50	60	70	80	90	100	110	120	130	140	150	175	200
X1	0.56	0.65	0.74	0.83	0.91	1.00	1.06	1.08	1.12	1.16	1.20	1.29	1.37
Inlet Temperature (°F)	70	80	90	100	105	110	115	120	-	-	-	-	-
X2	1.12	1.09	1.06	1	0.93	0.86	0.8	0.75	-	-	-	-	-



Ozen Air Filtration
Water Separation and
Service Elements



OFLG Series Compressed Air Filters

OFLG (12-1600 scfm)



Compressed air may be contaminated with oil, dust or water. If the air goes to the production line without being filtered, it can affect the quality of the final product and, hence, your reputation.

The OFLG series of compressed air filters are designed to satisfy increased quality demands and to provide high-quality air. Designed in four different models, the air filters can clean particles as small as 0.01 micron at a maximum pressure of 290 psi. The pipe sizes range from 1/4" to 3" NPT/BSP. The standard pressure drop indicator provides energy savings and facilitates maintenance. Zero-porosity aluminum, corrosion-resistant inner coating and durable powder paint offer long service life. All filters comply with PED and ISO 8573 standards.

- Superior protection from 5 microns to 0.01 micron.
- Easy element replacement thanks to snap on design.
- High efficiency and low pressure drop with deep pleats.
- The interlocked helical metal drives the air vertically to increase performance, while making the product more crush-resistant.
- Easier oil and water evacuation with the PVC impregnated foam.
- No more additional fixtures and piping thanks to joint clamps.
- Designed for easy assembly and replacement with zero clearance.
- With its anodic coating, it is resistant to corrosion and superior to competitors.



**TO REMOVE THE ELEMENT
TWIST CLOCKWISE**





Model	Capacity scfm	Coupling Size	Max Working Pressure psi	Element Model	Housing Dimensions (inch)				
					A	B	C	D	E
OFLG-12	12	1/4"	290	OFGM-12	3.0	1.7	7.6	6.8	0.27
OFLG-15	15	1/4"	290	OFGM-15	4.0	1.7	8.4	7.6	0.27
OFLG-24	24	3/8"	290	OFGM-24	3.0	1.7	7.6	6.8	0.27
OFLG-30	30	3/8"	290	OFGM-30	4.0	1.7	8.4	7.6	0.27
OFLG-60	60	1/2"	290	OFGM-60	4.0	1.7	10.0	9.0	0.27
OFLG-90	90	3/4"	290	OFGM-90	4.8	1.7	11.7	10.6	0.32
OFLG-120	120	3/4"	290	OFGM-120	4.8	1.7	14.2	13.0	0.32
OFLG-150	150	1"	290	OFGM-150	4.8	1.7	15.8	14.7	0.32
OFLG-175	175	1 1/4"	290	OFGM-175	4.8	1.7	18.0	16.6	0.32
OFLG-300	300	1 1/4"	290	OFGM-300	4.8	1.7	19.2	17.8	0.32
OFLG-350	350	1 1/2"	290	OFGM-350	4.8	1.7	21.0	19.6	0.35
OFLG-500	500	2"	290	OFGM-500	6.3	1.7	24.5	22.9	0.35
OFLG-700	700	2"	290	OFGM-700	6.3	1.7	27.2	25.6	0.35
OFLG-900	900	2 1/2"	290	OFGM-900	7.6	1.7	28.5	26.3	0.40
OFLG-1100	1100	3"	290	OFGM-1100	7.6	1.7	34.0	31.8	0.40
OFLG-1300	1300	3"	290	OFGM-1300	7.6	1.7	36.2	34.0	0.45
OFLG-1600	1600	3"	290	OFGM-1600	7.6	1.7	41.9	40.0	0.45

Filtering Specifications

Pre Filtering

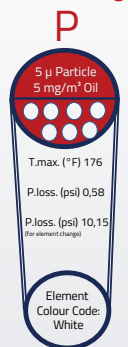

General Purpose

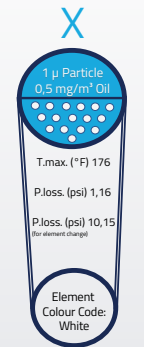

Oil Removal

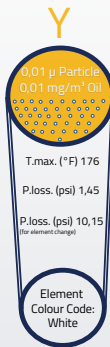

Activated Carbon

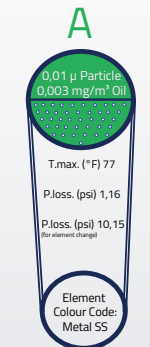

DRAIN TYPE
Electro-adjustable
External float type
Zero-loss drain
Manual

INDICATOR TYPE
Gauge with or without electrical contact

CORRECTION FACTORS FOR ODRR DRYERS											
Operating Pressure (psi)	15	44	73	100	131	160	189	218	232	261	290
X1	0.50	0.71	0.87	1.00	1.12	1.22	1.32	1.44	1.50	1.57	1.63

Notes:

- 1) Grade A must not operate in oil saturated conditions.
- 2) Grade A elements should be replaced periodically to suit the applications but must be changed at least every six months.
- 3) Grade A will not remove certain gases including carbon monoxide and carbon dioxide. Please refer to works if in doubt.
- 4) Flow rates are based certain gages including carbon monoxide and carbon dioxide. Please refer to works if in doubt.
- 5) All filters are suitable for use with mineral and synthetic oils.
- 6) Gauge type pressure indicators are fitted to models OFLG-12 to OFLG-1600 as standart.
- 7) All filters are in comformity with the Pressure Equipment Directive (97/23/ec)

OFLHG-H Series High Pressure Compressed Air Filters

OFLHG-H (60-1750 scfm)



OFLHG-H series high pressure air filters provide high-quality air as required by high-pressure applications. The reinforced wall thickness used in the products ensures high pressure performance.

OFLHG series 725 psi

- It is made of aluminum.
- It is strong and durable with its weldless design.
- The inner and outer surfaces of the filters have anodic coating.
- Manual brass discharge.

OFLHG-H series 5075 psi

- It is made of carbon steel.
- It can be used safely in high pressure applications with its weldless design.
- The inner and outer surfaces of the filters are painted with epoxy electrostatic powder paint.
- Manual brass discharge.



Technical Specifications

Model	Capacity	Coupling Size	Max Working Pressure	Element Model	Housing Dimensions (inch)				
					A	B	C	D	E
OFLHG 100	60	1/4"	725	OHGM-25	4.17	4.68	1.18	3.46	8.00
OFLHG 300	175	1/2"	725	OHGM-50	4.17	4.68	1.18	3.46	8.00
OFLHG 600	350	3/4"	725	OHGM-100	4.17	4.68	1.18	3.46	8.00
OFLHG 850	500	1"	725	OHGM-150	4.84	5.51	1.55	4.00	14.00
OFLHG 1200	700	1"	725	OHGM-200	4.84	5.51	1.55	4.00	14.00
OFLHG 1600	950	1 1/2"	725	OHGM-250	4.84	5.51	1.55	4.00	14.00
OFLHG 2500	1500	2"	725	OHGM-2500	6.25	7.00	2.20	5.23	15.00
OFLHG 3000	1750	2 1/2"	725	OHGM-3000	6.25	7.00	2.20	5.23	15.00
OFLHG-H 100	60	1/4"	5075	OHGM-25	4.46	4.54	1.01	6.10	1.50
OFLHG-H 300	175	1/2"	5075	OHGM-50	4.46	4.54	1.01	6.24	1.50
OFLHG-H 600	350	3/4"	5075	OHGM-100	4.30	4.54	1.26	8.14	2.00
OFLHG-H 850	500	1"	5075	OHGM-150	5.23	5.43	1.47	9.84	2.00
OFLHG-H 1200	700	1"	5075	OHGM-200	5.23	5.43	1.47	12.36	2.00
OFLHG-H 1600	1317	1 1/2"	5075	OHGM-250	5.03	5.43	1.74	14.48	2.00
OFLHG-H 2500	2058	2"	5075	OHGM-2500	5.70	6.22	2.02	15.47	2.00
OFLHG-H 3000	2470	2 1/2"	5075	OHGM-3000	6.29	7.00	2.26	15.19	2.00

Filtering Specifications

Pre Filtering

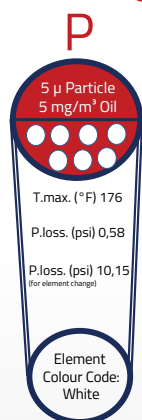

General Purpose

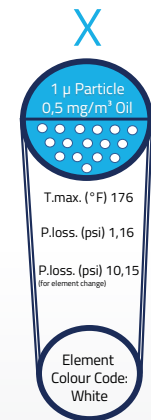

Oil Removal

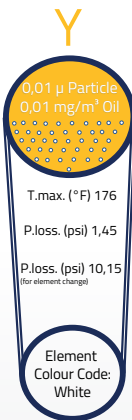

Activated Carbon

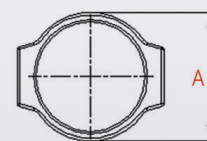
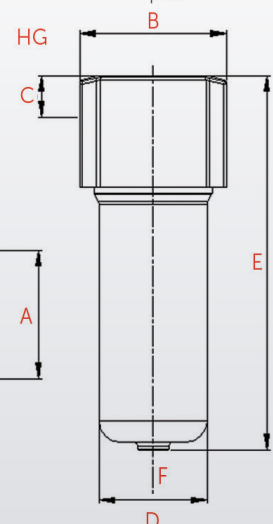
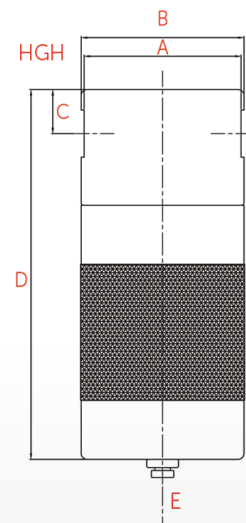
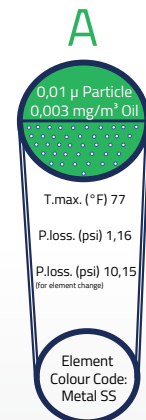

Notes:

- 1) Grade A must not operate in oil saturated conditions.
- 2) Grade A elements should be replaced periodically to suit the applications but must be changed at least every six months.
- 3) Grade A will not remove certain gases including carbon monoxide and carbon dioxide. Please refer to works if in doubt.
- 4) All filters are suitable for use with mineral and synthetic oils.
- 5) Other standards for flanged connections are available.
- 6) Direction of air flow, inside to out, through filter element, except P & A filter.

OWSG Series Water Separators

OWSG (15-1300 scfm)



OWSG series water separators, which are designed to eliminate the water droplets and particles found in compressed air and gases, have aluminum bodies. With their unique design, they generate a continuous centrifugal force and remove wastes with a very low pressure difference, providing maximum energy saving.

While highly effective, water separators cannot remove 100% of the oil in the air. The remaining oil, water and particles should be removed using an additional filter in the system.

- Aluminum body
- Wide range of products with joint diameters ranging from 1/4" to 3" and flow rates of up to 1294 scfm
- Standard automatic discharge
- Internal and external surfaces painted with electrostatic powder paint

Technical Specifications

Model	Capacity scfm	Coupling Size	Max Working Pressure psi	Housing Dimensions (inch)			
				A	B	C	D
OWSG-15	15	1/4"	230	4.00	10.10	9.30	6.30
OWSG-60	60	1/2"	230	4.00	10.10	9.30	8.20
OWSG-120	120	3/4"	230	4.80	12.00	10.90	11.20
OWSG-175	175	1"	230	4.80	12.00	10.90	15.00
OWSG-350	350	1 1/2"	230	4.80	12.60	11.20	18.50
OWSG-700	700	2"	230	6.30	19.00	17.40	22.00
OWSG-1300	1300	3"	230	7.60	21.50	19.30	24.00

- Max. Recommended Operating Temperature: 176 °F
- Min. Recommended Operating Temperature: 35 °F
- Typical Pressure Loss at Rated Flow: 0,7 psi

CORRECTION FACTORS FOR ODRD DRYERS									
Operating Pressure (barg)	1	3	5	7	9	11	13	15	16
PSIG	15	44	73	100	131	160	189	218	247
X1	0.50	0.71	0.87	1.00	1.12	1.22	1.32	1.44	1.57

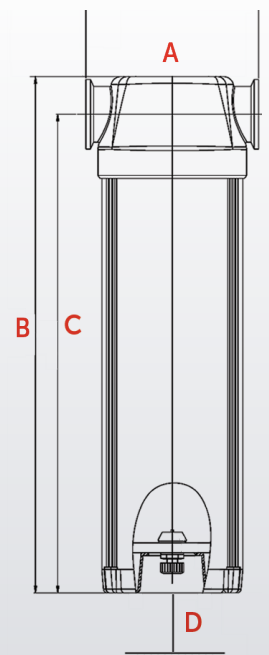

OWSF Series Flanged Water Separators



OWSF (1500-8300 scfm)



Built to eliminate water droplets and particles from compressed air and gases, the OWSF series flanged water separators have a unique design that helps create a continuous centrifugal force and eliminate the wastes with a very low pressure difference. This will save you energy.

There is a wide selection of products with a flange connection diameter range of DN80 PN16-DN 200, and up to 8236 scfm flow rates. While being highly effective, water separators cannot remove 100% of the oil in the air. The remaining oil, water and particles should be removed using an additional filter in the system.

Technical Specifications

Model	Capacity scfm	Coupling Size	Max Working Pressure psi	Housing Dimensions (inch)					
				A	B	C	D	E	F
OWSF-1500	1500	3" Flange	200	7.80	36.70	17.70	2.90	11.00	50.70
OWSF-1900	1900	4" Flange	200	8.60	37.90	17.70	2.90	11.00	52.00
OWSF-2500	2500	4" Flange	200	8.60	36.50	20.80	2.90	11.00	50.50
OWSF-3800	3800	6" Flange	200	11.20	43.00	22.80	2.90	11.00	57.00
OWSF-500	500	6" Flange	200	11.20	43.00	25.60	2.90	11.00	57.00
OWSF-6500	6500	8" Flange	200	13.30	46.00	29.50	2.90	11.00	60.00
OWSF-8300	8300	8" Flange	200	13.30	47.20	31.50	2.90	11.00	61.20

Max. Recommended Operating Temperature: 176 °F
 Min. Recommended Operating Temperature: 35 °F
 Typical Pressure Loss at Rated Flow: 0,7 psi

CORRECTION FACTORS FOR ODRD DRYERS								
Operating Pressure (barg)	1	3	5	7	9	11	13	14
PSIG	15	44	73	100	130	160	189	200
X1	0.50	0.71	0.87	1.00	1.12	1.22	1.32	1.38

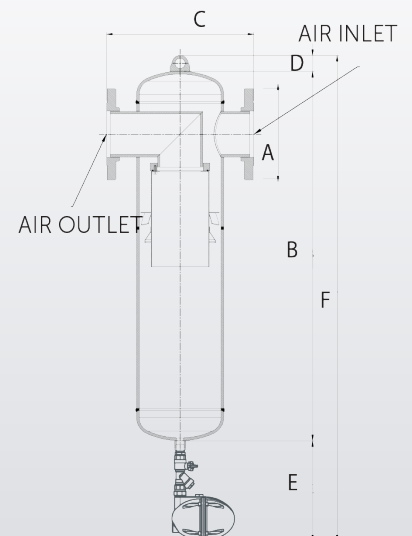
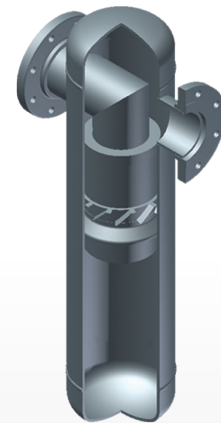

OELM Series High Efficiency Mist Eliminating Air (Mist Eliminator)

OELM (150-12000 scfm) / OELMH (150-600)



Designed to remove the oil particles and steam found in pressurized air, the OELM series oil mist eliminators are ideal for oil-injection compressors, vacuum pumps and blowers. It is used in many applications such as vacuum freeze drying, vacuum degassing, food processing, nail-punch guns, industrial vacuum processes, cement and paper processing.

Designed to effectively remove oil particles and steam from oil-injection compressors, the OELM series is characterized by long service life and durability under tough operating

- Superior oil catching efficiency
- Easy area cleaning
- Positive leak-proof O-ring
- Continuous operation within the temperature range of minimum 36 °F and maximum 176 °F
- Standard automatic float discharge
- Multiple discharge options
- Ability to withstand 200 psig pressure (OELM) 600 psig (OELMH)
- Removal of particles as small as 0.01 micron including coalesced liquid water and oil providing a maximum remaining oil aerosol content of 0.01 ppm
- Thanks to the increased surface area, ultra-thin oil mist is separated at low speed.
- Tin box grounded elements minimize problems related to static electricity.

Element

- Provides energy saving with very low pressure drop.
- Positive leak-proof seals eliminate the media bypass
- Long service life
- Filter change is needed when pressure difference of 2.5 psig occurs.



Technical Specifications

Model	Capacity scfm	Coupling Size Drain Port	Coupling Size Inlet/Outlet	Max Working Pressure psi	Housing Dimensions (inch)							
					A	B	C	D	ØE	ØF	G	H
OELM-150	150	1/2"	2" Flange	200	19.70	39.87	8.34	18.20	17.00	4.00	12.00	13.00
OELM-300	300	1/2"	2" Flange	200	19.70	43.87	8.34	22.20	17.00	4.00	16.00	17.00
OELM-600	600	1/2"	2" Flange	200	19.70	57.87	8.34	36.20	17.00	4.00	30.00	31.00
OELM-800	800	1/2"	3" Flange	200	19.70	65.27	11.10	42.80	17.00	4.00	36.00	37.00
OELM-1200	1200	1/2"	3" Flange	200	23.60	60.17	11.15	36.75	19.00	4.00	30.00	31.00
OELM-1600	1600	1/2"	3" Flange	200	23.60	66.17	11.15	42.85	19.00	4.00	36.00	37.00
OELM-2100	2100	1/2"	4" Flange	200	27.56	62.42	13.30	37.50	22.30	5.00	30.00	31.00
OELM-2750	2750	1/2"	4" Flange	200	27.56	68.42	13.30	43.43	22.30	5.00	36.00	37.00
OELM-4200	4200	1/2"	6" Flange	200	31.50	65.67	15.40	38.63	24.30	7.10	30.00	31.00
OELM-6000	6000	1/2"	6" Flange	200	31.50	75.67	15.40	48.67	24.30	7.10	37.40	41.00
OELM-8000	8000	1/2"	8" Flange	200	33.50	79.42	16.30	50.20	26.30	9.17	40.00	41.00
OELM-10000	10000	1/2"	10" Flange	200	39.40	83.47	18.90	51.55	30.30	13.20	40.00	41.00
OELM-12000	12000	1/2"	12" Flange	200	39.40	105.92	19.65	72.80	30.30	13.20	60.00	61.00
OELMH-150	150	1/2"	2" Flange	600	19.70	39.87	8.34	18.20	17.00	4.00	12.00	13.00
OELMH-300	300	1/2"	2" Flange	600	19.70	43.87	8.34	22.20	17.00	4.00	16.00	17.00
OELMH-600	600	1/2"	2" Flange	600	19.70	57.87	8.34	36.20	17.00	4.00	30.00	31.00

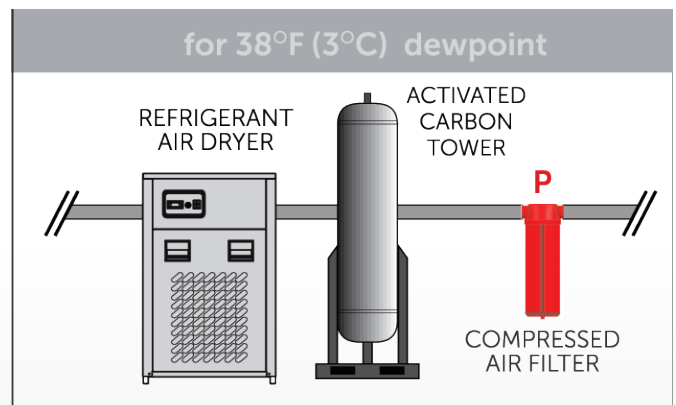
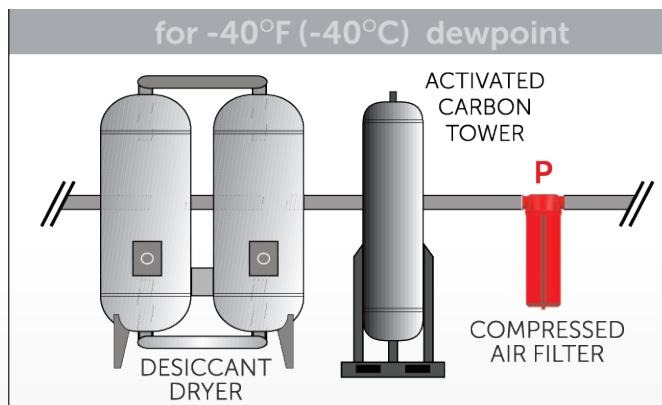

CORRECTION FACTORS FOR ODRD DRYERS								
Operating Pressure (barg)	1	3	5	7	9	11	13	14
PSIG	15	44	73	100	130	160	189	200
X1	0.50	0.71	0.87	1.00	1.12	1.22	1.32	1.38

For maximum flow rate, multiply model flow rate show in the above table by the correction factor corresponding to the working pressure.

DRAIN TYPE
Electro-adjustable
External float type
Zero-loss drain
Manual

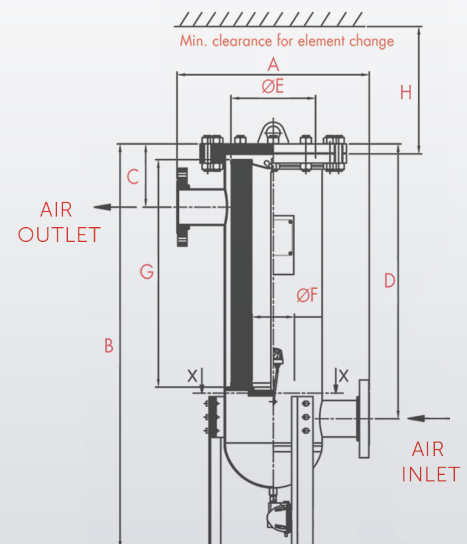

OFLF Series High Capacity Flanged Compressed Air filter

OFLF (1500-17700 scfm)



Built to provide high-quality air, the OFLF series high-capacity flanged compressed air filters, with their unique design, perform pre-separation. Two external float drains are used to ensure perfect drainage. The element which is placed into the filter by tie rod system can be easily changed from the upper closure. Tanks according to ASME standards are used in the OFLF series.

External Automatic Float Drain

- Specially designed external float drains easily drain the liquid collected at certain points.
- With epoxy powder coating on the outside and anodic coating on the inside, it is resistant to corrosion.

Technical Specifications

Model	Capacity scfm	Coupling Size Drain Port	Coupling Size Inlet/ Outlet	Max Working Pressure psi	Element Type	Number of Elements	Housing Dimensions (inch)				
							A	B	C	D	E
OFLF-1500	1500	1/2"	3" Flange	200	OHGM-1200	2	17.70	51.00	11.00	29.50	25.50
OFLF-1900	1900	1/2"	4" Flange	200	OHGM-1200	3	17.70	52.20	11.00	30.30	25.50
OFLF-2500	2500	1/2"	4" Flange	200	OHGM-1200	4	20.90	53.20	11.10	30.40	25.50
OFLF-3800	3800	1/2"	6" Flange	200	OHGM-1200	6	22.80	56.40	13.10	31.40	25.50
OFLF-5000	5000	1/2"	6" Flange	200	OHGM-1200	8	25.60	57.10	13.25	31.56	25.50
OFLF-6500	6500	1/2"	8" Flange	200	OHGM-1200	10	29.50	59.60	14.50	32.60	25.50
OFLF-8300	8300	1/2"	8" Flange	200	OHGM-1200	14	31.50	60.70	15.00	32.70	25.50
OFLF-10000	10000	1/2"	10" Flange	200	OHGM-1200	16	33.50	64.00	16.30	33.84	25.50
OFLF-12400	12400	1/2"	12" Flange	200	OHGM-1200	17	33.50	66.00	17.50	34.80	25.50
OFLF-15000	15000	1/2"	14" Flange	200	OHGM-1200	23	39.40	69.70	18.90	35.80	25.50
OFLF-17700	17700	1/2"	14" Flange	200	OHGM-1200	28	39.40	69.70	18.90	35.80	25.50

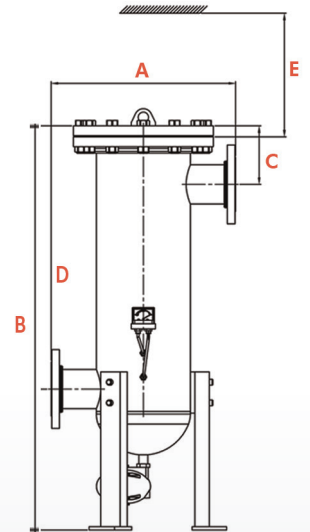

CORRECTION FACTORS FOR ODRY DRYERS								
Operating Pressure (barg)	1	3	5	7	9	11	13	14
PSIG	15	44	73	100	130	160	189	200
X1	0.50	0.71	0.87	1.00	1.12	1.22	1.32	1.38

DRAIN TYPE
Electro-adjustable
External float type
Zero-loss drain
Manual

Filtering Specifications

Pre Filtering

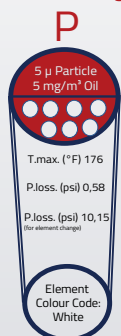

General Purpose

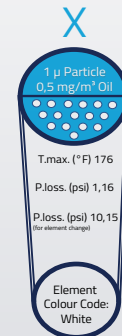

Oil Removal

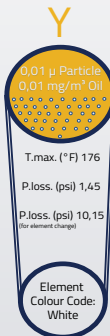

Activated Carbon

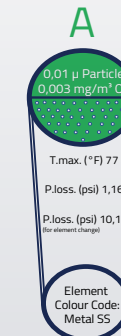

Notes:

- 1) Grade A must not operate in oil saturated conditions.
- 2) Grade A will not remove certain gases including carbon monoxide and carbon dioxide. Please refer to works if in doubt.
- 3) Flow rates are based certain gages including carbon monoxide and carbon dioxide. Please refer to works if in doubt.
- 4) All filters are suitable for use with mineral and synthetic oils.
- 5) Direction of air flow, inside to out, through filter element.



Nitrogen Generator



Nitrogen Generator

OANG (10-11200 scfm)



Ozen Air Technology PSA (Pressure Swing Adsorption) type nitrogen generators are designed for the on-site production of nitrogen gas, which is used in many fields from food packaging to laser cutting, and from electronics to chemistry and pharmaceutical industry. On-site nitrogen production helps reduce your operating costs while increasing your productivity.

Nitrogen generator consists of two tanks that include Carbon Molecular Sieves (CMS) as adsorbent, a valve group, air filters, pressure regulator, another tank for storage and balancing. The Carbon Molecular Sieve located in the tank keeps the oxygen and water vapor molecules in its pores to produce a nitrogen gas of 95% to 99.999% purity.

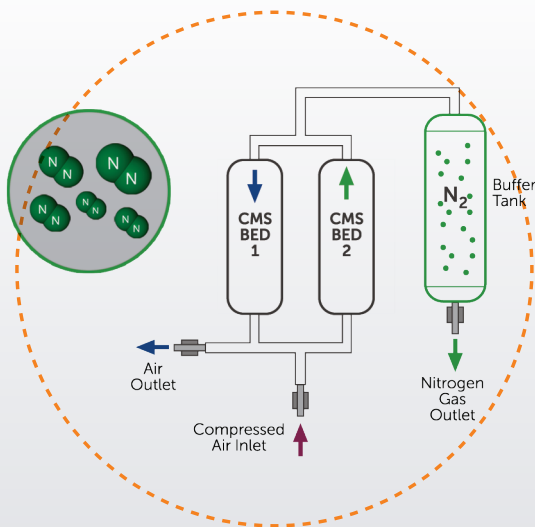

Advantages

- High reliability, low cost
- 7/24 on-site nitrogen production
- Control of the whole system from a single point with touch-screen control unit
- PLC screen for process control and tracking
- Compact design, fully automatic system
- High purity (95% - 99.999%) nitrogen production compatible with customer demands
- Innovative muffler designs and safe system (low noise level during depressurization processes)
- Durable piston valves
- Easy installation, high performance
- Minimum maintenance cost (filter replacement should be done periodically)

Standard accessories

- Activated carbon tower and muffler
- P type (particle) compressed air filtration after activated carbon tower and storage tank
- Crouzet Mini or Basic Logo PLC screen in modular models
- Siemens PLC color touchscreen in twin tower models
- Buffer tank

Optional accessories

- Oxygen analyzer
- Flowmeter
- Dew-point sensor
- Screen showing nitrogen purity

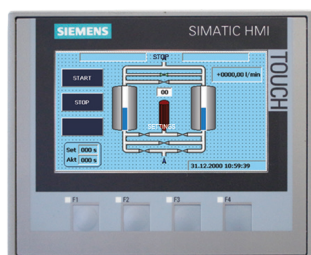

Touch Screen PLC



Long Life Piston Valve



Dew point Sensor

Technical Specifications

Model	Inlet Compressed Air Pressure psi	Outlet Nitrogen Pressure psi	Free Nitrogen Delivery @ Following Purity Level (scfm)										
			95%	97%	98%	99%	99,50%	99,90%	99,95%	99,99%	99,999%		
OANG-10	109	87	1.6	1.3	1.1	0.9	0.6	0.5	0.4	0.3	0.1	Modular	
OANG-20	109	87	2.6	2.1	1.8	1.4	1.2	0.7	0.7	0.5	0.2		
OANG-35	109	87	4.8	3.8	3.3	2.6	2.1	1.4	1.2	0.8	0.4		
OANG-60	109	87	7.9	6.3	5.5	4.3	3.5	2.3	2.0	1.4	0.7		
OANG-95	109	87	13.7	10.9	9.5	7.4	6.1	3.9	3.4	2.4	1.2	Twin Tower	
OANG-120	109	87	18.3	14.6	12.7	9.9	8.2	5.2	4.6	3.2	1.6		
OANG-150	109	87	22.4	17.9	15.6	12.1	10.0	6.4	5.6	3.9	2.0		
OANG-250	109	87	35.6	28.4	24.7	19.3	15.9	10.1	9.0	6.2	3.1		
OANG-330	109	87	47.1	37.6	32.7	25.5	21.1	13.4	11.8	8.3	4.1		
OANG-450	109	87	63.6	50.8	44.3	34.4	28.5	18.1	16.0	11.2	5.6		
OANG-510	109	87	72.9	58.2	50.7	39.4	32.6	20.7	18.3	12.8	6.4		
OANG-570	109	87	80.9	64.7	56.3	43.8	36.2	23.0	20.4	14.2	7.1		
OANG-730	109	87	105.9	84.6	73.7	57.3	47.4	30.2	26.7	18.6	9.3		
OANG-910	109	87	129.6	103.5	90.1	70.1	58.0	36.9	32.6	22.8	11.4		
OANG-1110	109	87	157.5	125.9	109.6	85.3	70.5	44.8	39.7	27.7	13.8		
OANG-1230	109	87	173.8	138.8	120.9	94.1	77.8	49.5	43.7	30.5	15.2		
OANG-1370	109	87	192.6	153.8	133.9	104.2	86.2	54.8	48.5	33.8	16.9		
OANG-1820	109	87	260.4	208.0	181.1	140.9	116.6	74.1	65.5	45.7	22.8		
OANG-2050	109	87	303.6	242.6	211.2	164.4	135.9	86.4	76.5	53.4	26.6		
OANG-2550	109	87	364.0	290.8	253.2	197.0	163.0	103.6	91.6	63.9	31.9		
OANG-2950	109	87	449.0	358.7	312.3	243.0	201.0	127.8	113.0	78.9	39.4		
OANG-3540	109	87	526.2	420.4	366.0	284.8	235.6	149.8	132.4	92.4	46.2		
OANG-4160	109	87	606.7	484.7	422.0	328.4	271.7	172.7	152.7	106.6	53.2		
OANG-5560	109	87	730.4	583.5	508.0	395.3	327.1	207.9	183.8	128.3	64.1		
OANG-9160	109	87	1204.7	962.4	837.9	652.0	539.4	342.9	303.2	211.6	105.7		
OANG-11200	109	87	1471.3	1175.5	1023.5	796.4	658.8	418.8	370.3	258.5	129.1		

Reference Contidions

Ambient Temperature	Inlet air dewpoint	
	38 °F (under 99.5% purity)	-40 °F (above 99.5% purity)
77 °F	Refrigerant air dryer and activated carbon filter is required	Desiccant air dryer and activated carbon filter is required

www.ozenairtech.com

Ozen Compressed Air Technology and Equipment LLC.
4205 Golf Acres Drive Charlotte NC 28208
Office (704) 660 0334
E-mail info@ozenairtech.com

